

M1 METER BOX HEAD
 BB30 Direct Fix - Bevel Back Weather Boards
 SCALE 1:2 @ A1, 1:4 @ A3

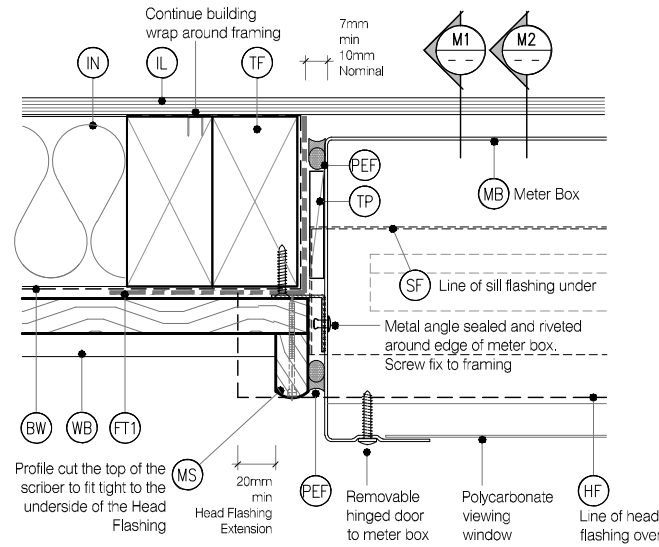

M3 METER BOX JAMB
 BB32 Direct Fix - Bevel Back Weather Boards
 SCALE 1:2 @ A1, 1:4 @ A3

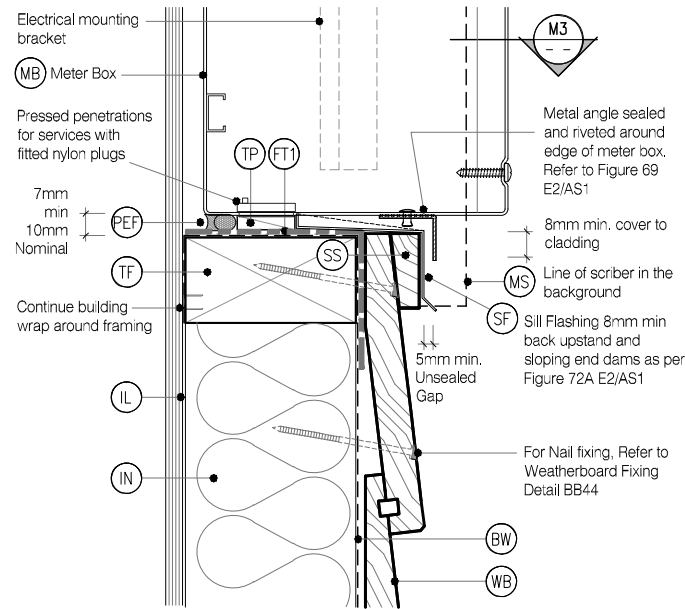

M2 METER BOX SILL
 BB31 Direct Fix - Bevel Back Weather Boards
 SCALE 1:2 @ A1, 1:4 @ A3

LEGEND :

- PEF** PEF ROD BACKING: Foam backing rod with sealant to cavity in meter box perimeter that forms a waterproof air-seal. (Sealant 2:1 Ratio)
- MB** METER BOX: Electrical meter box, with removable hinged door and polycarbonate viewing window
- IL** INTERNAL LINING: Selected Internal Lining
- BW** BUILDING WRAP: Flexible Wall Underlay, As per NZBC E2/AS1 - Table 23, In extra high wind zones, Rigid Underlay required (9.1.7.2 E2/AS1)
- SF** SILL FLASHING: Powder Coater Aluminium, with 8mm min back upstand and sloping end dams as per Figure 72A E2/AS1
- TP** TIMBER PACKER: MicroPro H3.2 Treated Packer
- FT1** FLASHING TAPE: Flashing tape over wrap 70mm (50 min) turn-down required in corners only. Refer to Fig. 72 of NZBC E2/AS1
- FT2** FLEXIBLE FLASHING TAPE: Flexible flashing tape lapped over aluminium head flashing or 2nd layer of Building Wrap to taped joint or top of frame
- TF** TIMBER FRAME: H1.2 min treated timber framing
- WB** WEATHER BOARD: KLC Generation II, MicroPro H3.2 Bevel Back Weatherboard. Profile to NZS 3617
- IN** INSULATION: Selected Insulation
- HF** HEAD FLASHING: Aluminium head flashing with minimum 15 degree fall and optional hemmed edges as per table 7 E2/AS1
- TP** TIMBER PACKER: MicroPro H3.2 Treated Packer
- WH** WEATHERHEAD: MicroPro H3.2, Horizontal batten above window as necessary to suit profile, shaped to shed water, sealant to back of sill scriber
- SS** SILL SCRIBER: MicroPro H3.2, Horizontal batten under meter box as necessary to suit profile
- MS** METER BOX SCRIBER: KLC Generation II, MicroPro H3.2 profile cut to fit weatherboard, sealant to back of scriber, 40x18 or 65x18 depending on weatherboard size

MicoPro® Wood Treatment Technology

- KLC use the MicroPro Micronized Copper Azole (MCA) based preservative system for their wood products. It accounts for 80% of wood treated in the US for domestic applications
- Micronized Copper Azole (MCA) preservatives are EPA-approved for use in NZ and AUS to NZS3610:2003 and AS1604.1:2012
- MicroPro preservative is applied using high-pressure and vacuum-pressure in the impregnation process in KLC's modern, automated treatment facility. Cut End Treatment : All cut ends surfaces are to be double coated and sealed before fixing. With a alkyl (oil based) primer
- MicroPro preservative solution has benefits of reduced corrosivity. Use Hot Dip Galvanised Fasteners & Stainless Steel fasteners. MicroPro may be placed in direct contact with Aluminium Building products in interior applications, and above ground exterior applications that provide proper water drainage
- MicroPro® is the first wood treatment process to be EPP (Environmentally Preferable Product) certified by Scientific Certification Systems based on a life cycle assessment.
- MicroPro® is environmentally sustainable, is low leaching, low VOC emissions and the award of the GREENGUARD Children and Schools' Certification from the Greenguard® Environmental Institute.
- MicroPro® Wood Treatment Technology has received a Global GreenTag GreenRate™ Level A this declaration is 'Fit-for-Purpose' and confirmed for Green Building compliance.
- MicroPro® Wood Treatment Technology has received GreenTag PHD™ proving claims that MicroPro® is safe for human health (and ecosystems).

HOW TO DETERMINE THE TIMBER WEATHERBOARD STRUCTURE :

RISK SCORE	DIRECT FIX	20mm CAVITY FIX
0 - 6	Timber Weather Boards (All Types)	(Not Required)
7 - 12	Bevel Back Timber WB Vertical Timber Board & Batten	Rusticated WB
13 - 20	(Direct Fix NOT Allowed)	Rusticated WB B.B Timber WB
20 +	(Redesign or Specific Design)	

Table 3 E2/AS1 are the minimum requirements, For extra security, you can always upgrade to a higher specification.

- NOTES:**
 Claddings in Extra High Wind Zones require:
 a. Rigid underlays to (Paragraph 9.1.7.2 E2/AS1)
 b. Drained Cavities to (Paragraph 9.1.8 E2/AS1)
 c. Hooks and Hems on flashing upstands and additional 25mm height to (Paragraph 4.6 E2/AS1)

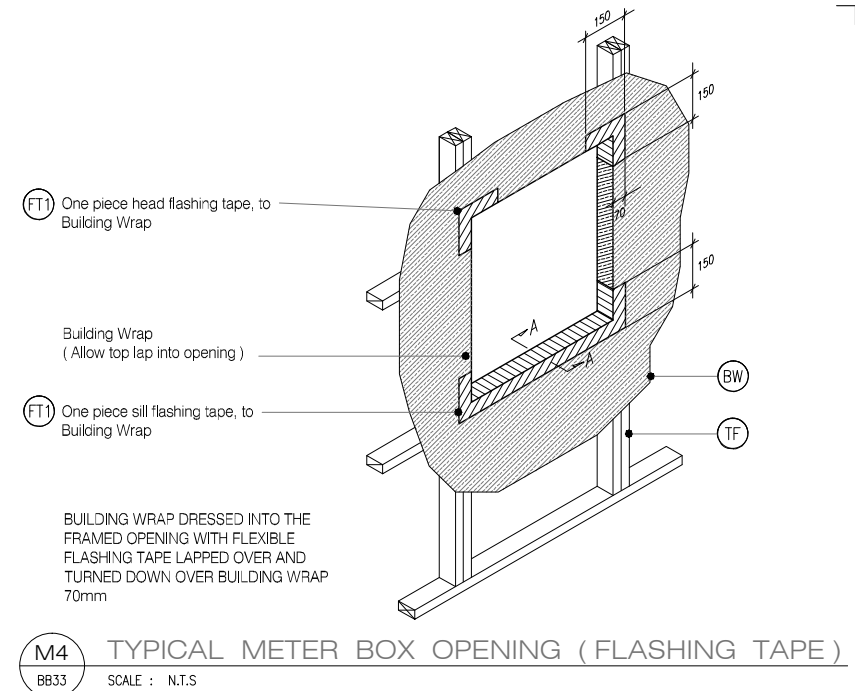

M4 TYPICAL METER BOX OPENING (FLASHING TAPE)
 BB33 SCALE : N.T.S

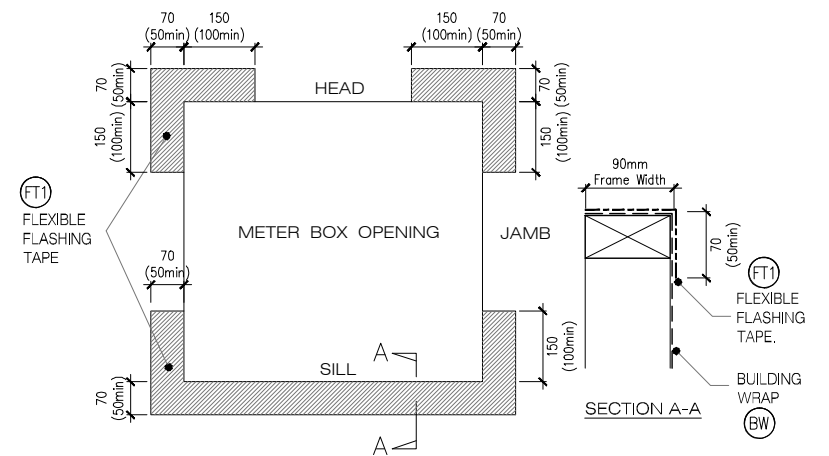

M5 FLEXIBLE BUILDING WRAP AT OPENING
 BB33 SCALE : 1 / 5 @ A1, 1 / 10 @ A3

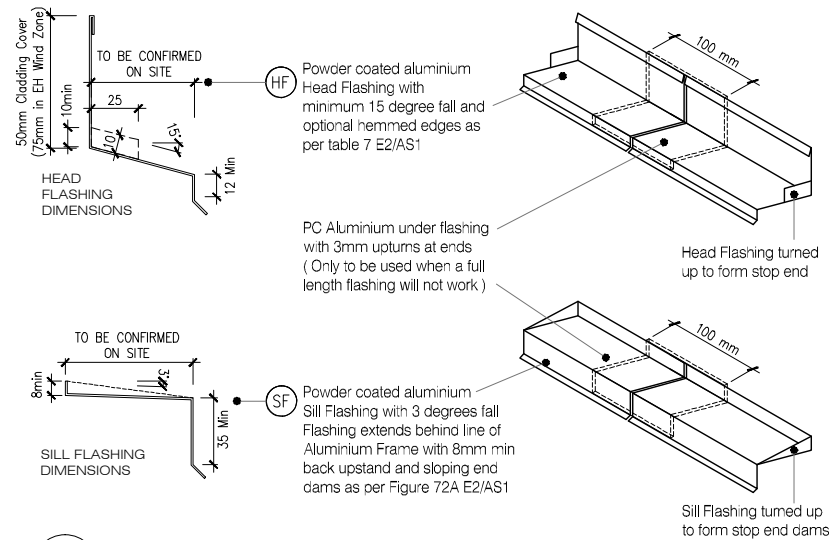

M6 TYPICAL HEAD & SILL FLASHINGS
 BB33 SCALE : 1 / 2 @ A1, 1 / 4 @ A3

CAD REF : KLC DF BB30-35 - METER BOX.dwg
 DATE : 20/11/2018